



URINARY FLOW MEASUREMENT DEVICE

Description

There are several diseases that can cause lower urinary obstruction. In men, urethral stenosis is a relatively frequent cause of lower urinary obstruction. This problem can affect women as well. Other causes may be a bladder with little capacity to contract or problems affecting the prostate, such as benign prostatic hyperplasia, which can make it difficult to pass urine from the bladder to the outside. This is one of the most common diseases in older men and the most common cause of lower urinary tract symptoms in men.

Measuring peak urine flow is especially useful in these situations, since, although it does not diagnose the specific disease, it allows us to distinguish between patients with normal urine flow, and patients with decreased urine flow.

Currently, this measurement is done frequently, in medical consultation with the limitations and inconveniences that this entails and needs equipment that requires the presence of health personnel.

Researchers from the University Miguel Hernández and the Hospital de Sant Joan d'Alacant, have developed a device for measuring peak urine flow that includes a collection container, a measuring pipe and a disposable test strip as a measurement and recording element.

The device can be especially useful for patients who have been shown to be prone to diseases that cause lower urinary obstruction. It can be a tool for daily use at home, helping to diagnose these diseases early, control their evolution and monitor the effect of medical or surgical treatments.

The device is easy to use, low cost, modular, adaptable, and hygienic.

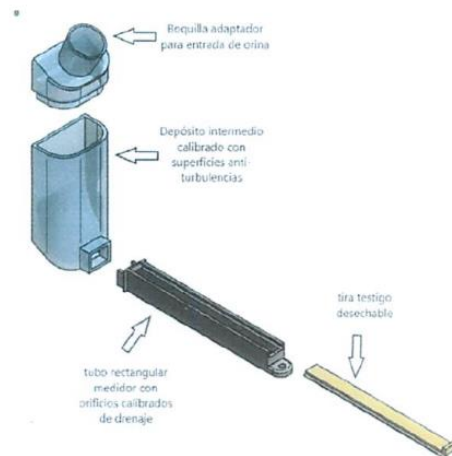

Technical Advantages

Urinary flow measurement devices used in specialized practices are often expensive, complex and use up part of the practice time. Moreover, because they are based on one-off measures and are performed in the presence of observers, they may be unrepresentative. There are some devices on the market that can be used at home by the patient. However, they are unreliable, unhygienic, and/or difficult to interpret. The device developed has several advantages:

- It can be used at home in an individual and simple way.
- Its modular design allows it to be disassembled into various parts for easy cleaning.
- It is reliable due to the hydraulics of the device.
- It has a reading method based on a disposable strip that is much easier to interpret, hygienic if it has to be kept, and facilitates tracking.
- It is a low-cost device.
- It allows the attachment of various accessories that facilitate their attachment to the toilet and their use in women.

State of development and Industrial Property Rights

We have a prototype manufactured by means of additive manufacturing, in plastic material, and its reliability and operation has been tested.

A Utility Model has been filed with the Spanish Patent and Trademark Office with number U201931877 and priority date 13/11/2019.

Schematic of the Urine Flow Measurement Device

Área de Innovación FISABIO

Ayda. Cataluña, 21
46020Valencia
innovación@fisabio.es
www.fisabio.es